

Quantum series



Q-3-T

DAS Audio Group, S.L. - C/ Islas Baleares 24 - 46988
Fuente del Jarro - Valencia - Spain - Tel. +34961340860
Updated (DD/MM/YYYY): 24/02/2025



SOUND WITH SOUL

KEY FEATURES

- Passive system
- Extruded aluminum enclosure
- 1 x 3", 3P full-range speaker
- Dispersion H x V: 120° x 120°
- SPL peak: 106 dB
- Multi-tap 100/70V transformer included
- Low/high-impedance operation
- Available in all RAL colors

DESCRIPTION

The Q-3-T is a highly compact and discrete system ideal for short distances, for creating ambience, and for frontfill and under-balcony sound reinforcement. Like the other systems in the series, the Q-3 has two operating modes (voice and music) that guarantee outstanding speech intelligibility and excellent music reproduction in any acoustic environment.

The aluminum enclosure and the IP-66 kit make this a highly reliable and durable choice, available in any RAL color.

Q-3-T

DAS Audio Group, S.L. - C/ Islas Baleares 24 - 46988
Fuente del Jarro - Valencia - Spain - Tel. +34961340860
Updated (DD/MM/YYYY): 24/02/2025



SOUND WITH SOUL

SPECIFICATIONS

Performance

Frequency Range (-10 dB)	150 Hz - 20 kHz
Horizontal Coverage (-6 dB)	120°
Vertical Coverage	120°
Nominal Impedance	8 ohms
Transformer Taps 70 V	3.5 W - 7.5 W - 10 W
Transformer Taps 100 V	7.5 W - 15 W - 20 W
RMS Power Handling	20 W
Peak Power Handling	80 W
On-axis Sensitivity 1W/1 m	87 dB SPL
Maximum Peak SPL at 1 m	106 dB SPL

Recommended Amplifier	INTEGRAL-A402
	INTEGRAL-A404
	INTEGRAL-A1002
	INTEGRAL-A1004
	INTEGRAL-A1602
	INTEGRAL-A1604
	INTEGRAL-MA1004
	INTEGRAL-MA1604

Recommended Processor	INTEGRAL-M88
	INTEGRAL-MA1604
	INTEGRAL-MA1004

Connectors

Audio Input Connector	4-way Phoenix 3.8 mm
-----------------------	----------------------

Q-3-T

Enclosure

Enclosure Construction	Aluminum
Color	Black
IP Rating	IP66
Depth	125 mm (4,9 in)
Dimensions (H x W x D)	105 x 125 x 125 mm 4,1 x 4,9 x 4,9 in
Net Weight	1,6 kg (3,5 lb)

Components

MF Driver	3P
-----------	----

DIMENSIONS

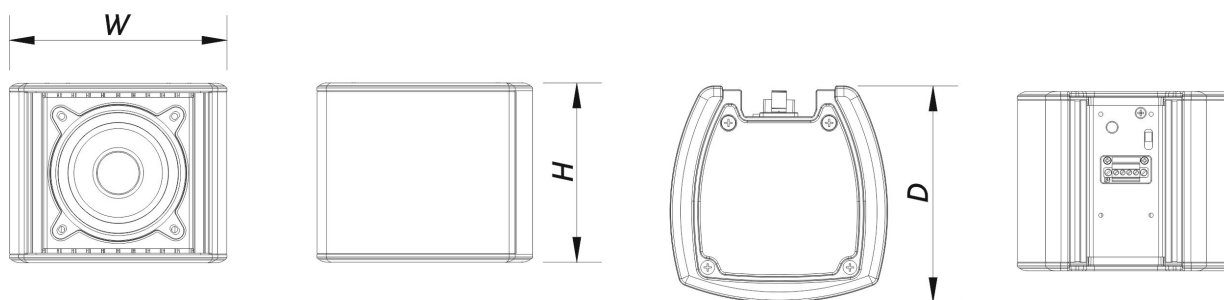

ORDERING INFORMATION

Model	Description	P/N
System		
Q-3-T		10434040

Q-3-T

DAS Audio Group, S.L. - C/ Islas Baleares 24 - 46988
Fuente del Jarro - Valencia - Spain - Tel. +34961340860
Updated (DD/MM/YYYY): 24/02/2025



Replacement Parts

3P	Cone Transducer	20208711
F-Q-3-T	Filter	20140140
LAMP-F-21	Lamp	30000535

Accessories

AXC-AT2	Installation & Stacking Acc.	10104311
AXC-Q	Installation & Stacking Acc.	10105146
AXC-ZT2	Installation & Stacking Acc.	10104325
AXW-4	Installation & Stacking Acc.	10104175
AXW-5	Installation & Stacking Acc.	10104176
JP-Q	Installation & Stacking Acc.	10102973
KIT-IP-Q	Installation & Stacking Acc.	10434090

Q-3-T

DAS Audio Group, S.L. - C/ Islas Baleares 24 - 46988
Fuente del Jarro - Valencia - Spain - Tel. +34961340860
Updated (DD/MM/YYYY): 24/02/2025



SOUND WITH SOUL