

Altea 700



ALTEA-S15A

DAS Audio Group, S.L. - C/ Islas Baleares 24 - 46988
Fuente del Jarro - Valencia - Spain - Tel. +34961340860
Updated (DD/MM/YYYY): 12/12/2024



SOUND WITH SOUL

KEY FEATURES

- Active bass-reflex subwoofer
- Class-D power amplifier with switching power supply
- 24-bit DSP with 2-channel signal routing
- DASControl™ display + encoder
- Cardioid-Presets
- Prepared for transport wheels
- PowerCon In/Out

DESCRIPTION

The ALTEA-S15A is a compact yet powerful active subwoofer with a bass-reflex design that delivers deep frequency response and impressive sound pressure levels.

The 15" DAS 15FW4 woofer boasts a high-quality construction with a 3" voice coil and die-cast aluminium basket, allowing for high excursion and a power handling of 600 watts/AES. An optimized ventilation system enables a high sustained load with extremely reduced power compression.

The woofer is driven by an integrated Class-D power amplifier with a wide-range switching power supply, providing 600 watts/RMS and 1200 watts/peak, enabling up to 131dB/max SPL with a frequency response of 40Hz to 125kHz.

The ALTEA-S15A also features an extensive range of settings to ensure the best possible performance. PowerCon In/Out power connections are included, while the integrated DSP with DAScontrol™ (LCD display+encoder) allows for adjustable crossover frequencies, two sound presets (deep/loud), and cardioid presets. With the cardioid presets you can quickly and easily create setups with multiple ALTEA-S15A units to reduce the sound energy emitted to the rear.

The ALTEA-S15A cabinet is constructed of high-quality birch plywood and finished with our rugged ISOflex™ PU coating. The high-quality front grille is powder-coated. For transport, in addition to two side handles, the ALTEA-S15A is prepared for the mounting of rear wheels.

ALTEA-S15A

DAS Audio Group, S.L. - C/ Islas Baleares 24 - 46988
Fuente del Jarro - Valencia - Spain - Tel. +34961340860
Updated (DD/MM/YYYY): 12/12/2024



SOUND WITH SOUL

SPECIFICATIONS

Performance

Frequency Range (-10 dB)	40 Hz - 125 Hz
Maximum Peak SPL at 1 m	131 dB

Electronics and Connectors

Nominal Amplifier Power (continuous)	600 W
Nominal Amplifier Power (peak)	1200 W
Input Type	Balanced
Input Impedance	20 kohms
Input Sensitivity	1.95 V (+8 dBu)
Audio Signal Input Connector	2 x Female XLR
Audio Signal Loop Thru Connector	2 x Male XLR
Control	DAScontrol™
AC Output Connector	powerCON NAC3MPB
Current Draw 230 V / 115 V	1.4 A/2.8 A

Enclosure

Enclosure Construction	Birch Plywood
Enclosure Geometry	Rectangular
Finish	ISO-flex Paint
Color	Black
Dimensions (H x W x D)	470 x 485 x 685 mm 18,5 x 19,1 x 27,0 in
Net Weight	30,0 kg (66,0 lb)

ALTEA-S15A

DAS Audio Group, S.L. - C/ Islas Baleares 24 - 46988
Fuente del Jarro - Valencia - Spain - Tel. +34961340860
Updated (DD/MM/YYYY): 12/12/2024



SOUND WITH SOUL

Components

LF Driver	15FW4
-----------	-------

Shipping

Carton Dimensions (H x W x D)	515 x 525 x 716 mm 20,3 x 20,7 x 28,2 in
Shipping Weight	35,0 kg (77,0 lb)

DIMENSIONS

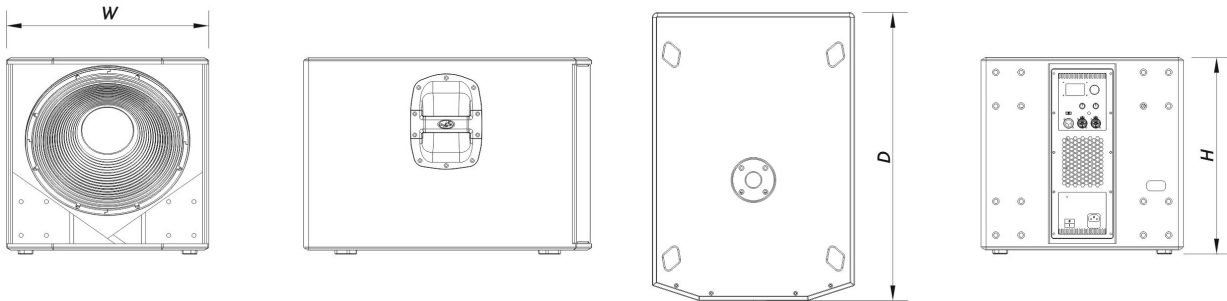

ORDERING INFORMATION

Model	Description	P/N
-------	-------------	-----

System

ALTEA-S15A		10404985
------------	--	----------

Replacement Parts

15FW4	Cone Transducer	20208986
DSP-EV115	Dsp	20406441
GM-15FW4	Recone Kit	20208537

ALTEA-S15A

DAS Audio Group, S.L. - C/ Islas Baleares 24 - 46988
Fuente del Jarro - Valencia - Spain - Tel. +34961340860
Updated (DD/MM/YYYY): 12/12/2024



SOUND WITH SOUL

MP-EV115A	Power Module	20405101
-----------	--------------	----------

Accessories

FUN-AL-S15	Transport Accessories	10103795
------------	-----------------------	----------

FUN-AL-S15-V	Transport Accessories	10103796
--------------	-----------------------	----------

KIT-W100	Transport Accessories	10104410
----------	-----------------------	----------

TRD-6	Installation & Stacking Acc.	10104470
-------	------------------------------	----------

TRD-7	Installation & Stacking Acc.	10104471
-------	------------------------------	----------

ALTEA-S15A

DAS Audio Group, S.L. - C/ Islas Baleares 24 - 46988
Fuente del Jarro - Valencia - Spain - Tel. +34961340860
Updated (DD/MM/YYYY): 12/12/2024



SOUND WITH SOUL