

# Quantum series



## Q-43-T

---

DAS Audio Group, S.L. - C/ Islas Baleares 24 - 46988  
Fuente del Jarro - Valencia - Spain - Tel. +34961340860  
Updated (DD/MM/YYYY): 17/09/2024



SOUND WITH SOUL

## KEY FEATURES

- Passive system
- Extruded aluminum enclosure
- 4 x 3", 3P16 full-range speaker
- Dispersion H x V: 120° x 30°/45°
- SPL peak: 118 dB
- Multi-tap 100/70V transformer included
- Low/high impedance operation
- Available in all RAL colors

## DESCRIPTION

This system is designed for small- and mid-sized venues. The vertical dispersion selection by means of the system-integrated filter (30°/45°) makes it possible to control the system's dispersion lobe in the vertical plane and thus reduce the reverb, improving intelligibility in spaces such as cultural centers, museums, conference rooms...all while delivering superb music reproduction.

The aluminum structure and the IP-66 kit make it a highly reliable and resistant choice, available in any RAL color.

# Q-43-T

---

DAS Audio Group, S.L. - C/ Islas Baleares 24 - 46988  
Fuente del Jarro - Valencia - Spain - Tel. +34961340860  
Updated (DD/MM/YYYY): 17/09/2024



SOUND WITH SOUL

## SPECIFICATIONS

### Performance

Frequency Range (-10 dB)	150 Hz - 20 kHz
Horizontal Coverage (-6 dB)	120°
Vertical Coverage	Switchable: 45° - 30°
Nominal Impedance	4 ohms
Transformer Taps 70 V	7.5 W - 15 W - 25 W
Transformer Taps 100 V	15 W - 30 W - 50 W
RMS Power Handling	80 W
Peak Power Handling	320 W
On-axis Sensitivity 1W/1 m	93 dB SPL
Maximum Peak SPL at 1 m	118 dB SPL
Recommended Amplifier	INTEGRAL-A402 INTEGRAL-A404 INTEGRAL-A1002 INTEGRAL-A1004 INTEGRAL-A1602 INTEGRAL-A1604 INTEGRAL-MA1004 INTEGRAL-MA1604
Recommended Processor	INTEGRAL-M88 INTEGRAL-MA1604 INTEGRAL-MA1004

### Connectors

Audio Input Connector	4-way Phoenix 3.8 mm
-----------------------	----------------------

# Q-43-T

## Enclosure

Enclosure Construction	Aluminum
Color	Black
IP Rating	IP66
Depth	125 mm (4,9 in)
Dimensions ( H x W x D )	355 x 125 x 125 mm 14,0 x 4,9 x 4,9 in
Net Weight	5,3 kg ( 11,7 lb )

## Components

MF Driver	3P16
-----------	------

## DIMENSIONS

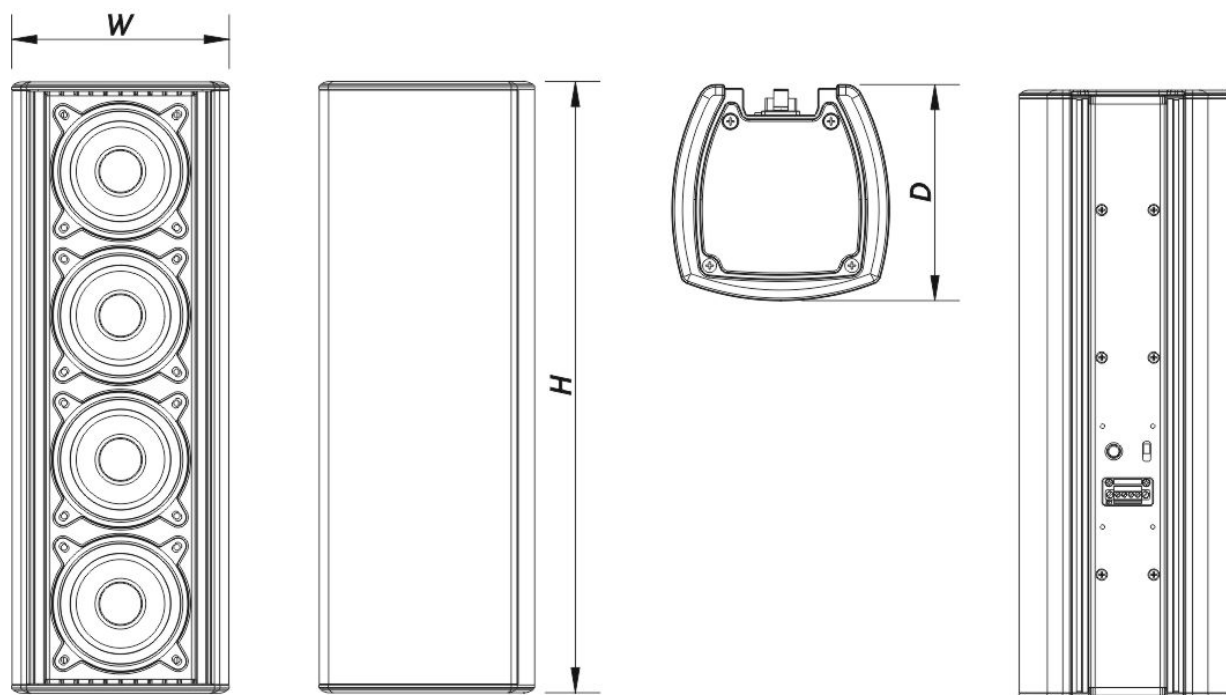

# Q-43-T

DAS Audio Group, S.L. - C/ Islas Baleares 24 - 46988  
Fuente del Jarro - Valencia - Spain - Tel. +34961340860  
Updated (DD/MM/YYYY): 17/09/2024



## ORDERING INFORMATION

Model	Description	P/N
<b>System</b>		
Q-43-T		10434060
<b>Replacement Parts</b>		
3P16	Cone Transducer	20208712
F-Q-43-T	Filter	20140142
LAMP-F-21	Lamp	30000535
<b>Accessories</b>		
AXC-AT2	Installation & Stacking Acc.	10104311
AXC-ZT2	Installation & Stacking Acc.	10104325
AXW-5	Installation & Stacking Acc.	10104176
AXW-6	Installation & Stacking Acc.	10104171
JP-Q	Installation & Stacking Acc.	10102973
KIT-IP-Q	Installation & Stacking Acc.	10434090

# Q-43-T

DAS Audio Group, S.L. - C/ Islas Baleares 24 - 46988  
Fuente del Jarro - Valencia - Spain - Tel. +34961340860  
Updated (DD/MM/YYYY): 17/09/2024



SOUND WITH SOUL